

Series Model

- SL-150C : Standard model, without lock status indicator output.
- ✘ This unit does not come with any other series.

Special features

- Holding force:143lbs(65Kg).
- Fail-safe (power to lock) electric lock.

- Use with bracket for different installation to see fit.
- Power input DC12V, it is also to be used with current lower than DC12V.
- Strong holding force. DC3V is able to obtain 15kg holding force.
- Low power consumption with high efficiency, noise-free.

Specification Dimensions

	SL-150C
Power Supply	DC 12V ±15%
Operation current	150mA@12VDC ± 15%
Application	Mailbox \ drawer \ locker
Holding forces	170lbs(80Kg)/ DC 12V
Operation temperature	40°C ± 5°C (Room temperature 30°C)
Operation environment	Temperature 0-80°C, Humidity 85%Rh max
Weight	635g (included wrapping)

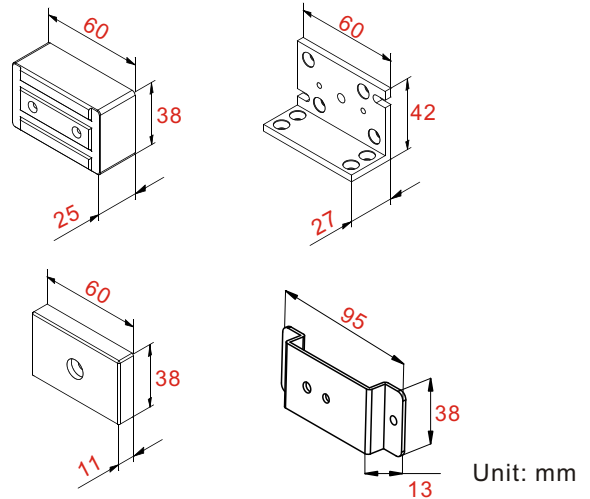

Structure diagram

5 installation methods available according to the environment.

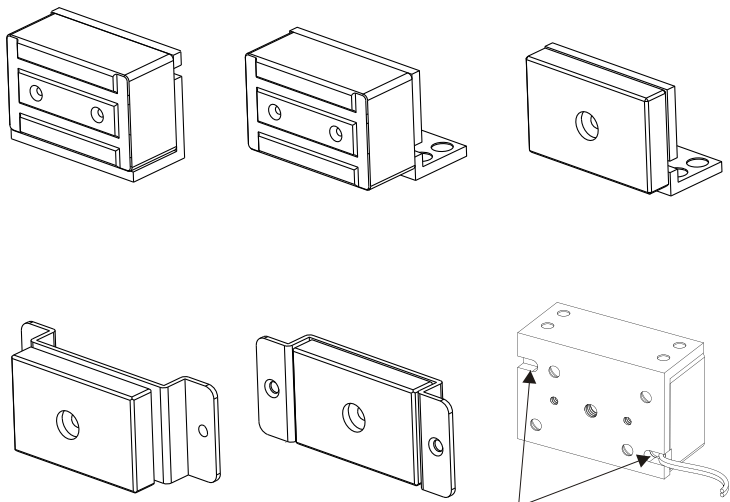

Adjustable wiring position

